

COBRA CLASS 26

Instruction Manual

1. Brief Introduction

It's designed with sliding lever thread take-up, vertical rotating hook to produce double lockstitch; gear band for driving arm shaft and hook shaft, lever type stitch regulator, compound feed by presser foot, feed dog and needle. And the clutch safe device is installed to prevent the damage. It is easy for sewing more lays leather with high presser foot lift, large stitch length and cylinder bed.

It's widely used for sewing heavy-duty luggage suitcase, seat cushion, especially for cylinder and curve articles. It's a essential equipment for edge seaming.

3. Installation

(1) Location of the machine

The machine must be located on rigid and flat floor for ensuring its smooth operation and reducing its vibration. Furthermore, a rubber mat should be inserted between the machine stand and the floor for further reducing the running noise.

(2) Install the arm bed and oil reservoir(Fig. 1)

At first, the four screw holes of the arm bed should align the four holes of the table and should be plunged through four bolts and tighten the nut. Then put the oil reservoir on the arm bed smoothly.

(3)Install the machine head(Fig. 2)

At frist, half of the hinges should be made to engage with the arm bed, then put the head lightly on the base of the head and move slightly. The three screw holes of the hinges of the head should be made to align with the three holes of the hinge and three screw will be tighten and fixed.

2. Main specification

Application	Medium, heavy and extra heavy
Max. Sewing speed	2200 s.p.m.
Stitch length	0-5mm
Needle bar stroke	33.2mm
Presser foot lift height	8.5mm by hand
	14mm by knee
Needle	DP×17 18#~23#
Rotating hook	Standard vertical hook
Lubrication	Manual
Motor	370W

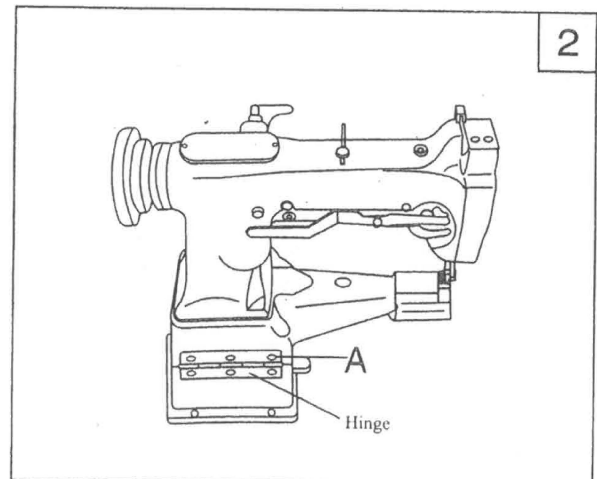
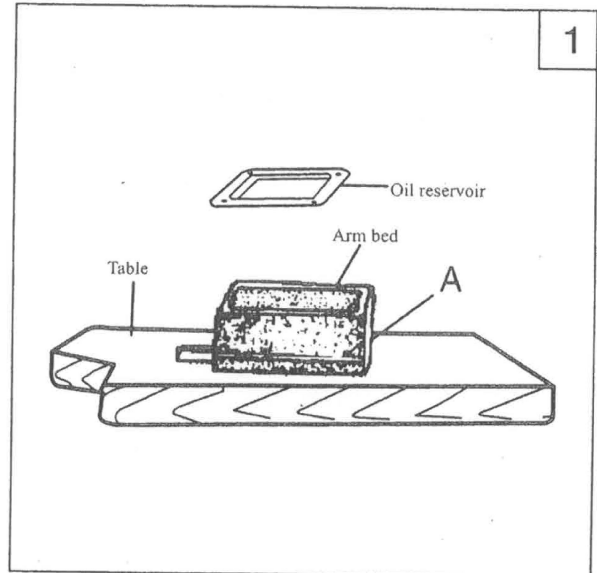

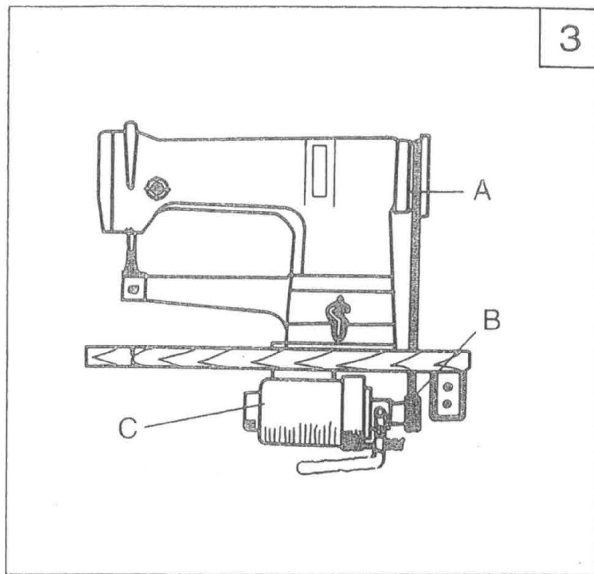

4. Installing the motor (Fig. 3)

Align machine balance wheel belt groove A with motor pulley belt groove B by moving motor C leftward or rightward. Be sure the belt is not touched with the table.

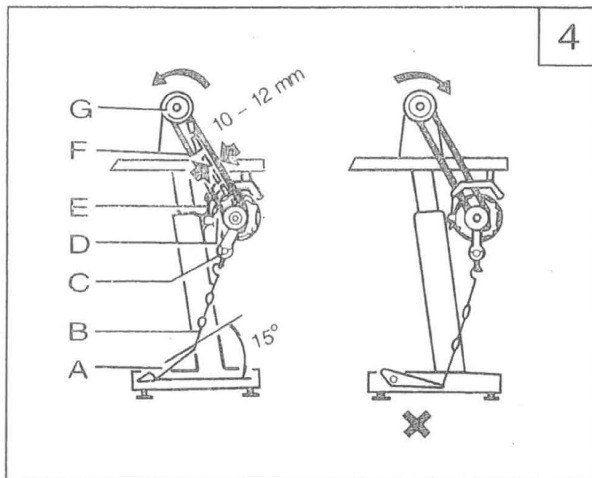

5. Connecting the clutch lever to the pedal (Fig. 4)

- 1) The optimum tilt angle of pedal A against floor is appropriate 15 degree.
- 2) Adjust the E clutch of the motor so that clutch lever C and draw bar B run in one line.
- 3) The machine balance wheel should rotate counter-clockwise for normal sewing when observed from opposite side of the balance wheel. The motor rotates in the same direction. The rotation can be reversed by reversing the plug of the motor.
- 4) Adjust the tension of V-belt F by moving vertically. The proper tension of V-belt is a slack of 10-12mm when the belt is depressed by forefinger.

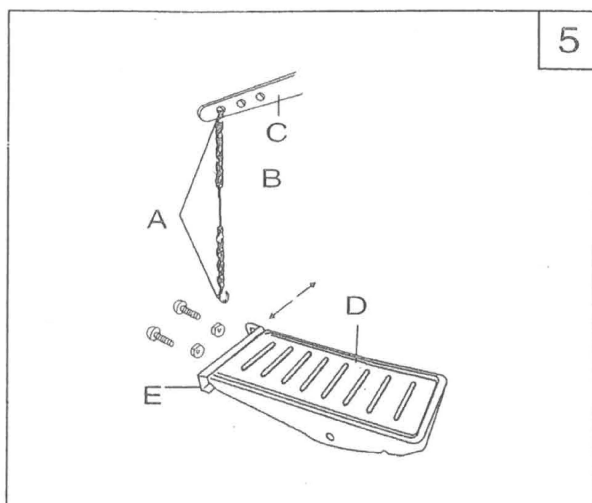

6. Installing the presser foot lift control plate (Fig. 5)

At first, the hook A should be connected to the chain B and presser foot lift lever C, then put the pedal complete D on the stand. And move the control plate E leftward or rightward until the chain becomes on one line. Tighten the bolts and nuts, finally, connect the finger to the control plate.

7. Installing the bobbin winder(Fig. 6)

Align pulley B of the bobbin winder with the outside of the belt C. And there should be a proper clearance between them, so that pulley B can be contacted with the belt when latch thumb lever A is depressed, thereby the belt can drive pulley B while the machine running. The bobbin winder should be parallel with belt slit E of the table, then fasten two wood screws D.

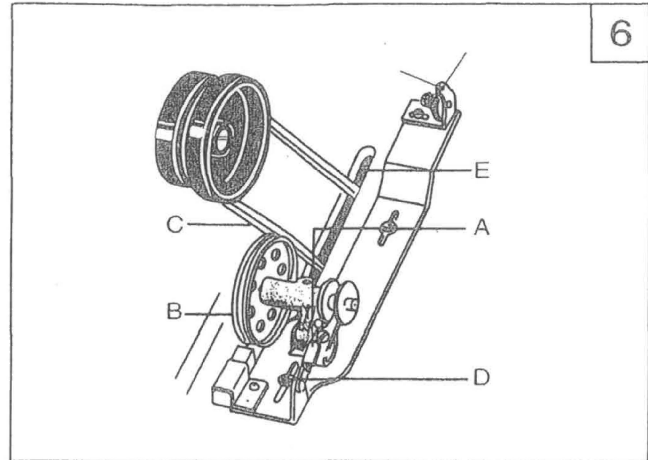

8. Installing the thread unwinder (Fig. 7)

The thread unwinder should be located on the right backside of the table. Threading should be smooth when sewing. And the spool rest may not be obstructed when the machine head is turned backward, then tighten wood screw C.

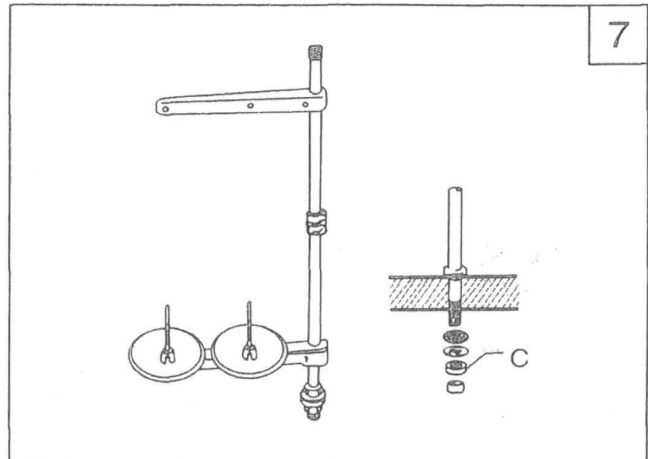

9. Preparation

(1) Cleaning the machine

Before the head is packed, all the parts of the machine are coated with preventive grease, meanwhile the hardened grease and converged dust on the machine surface during long storage and shipment must be removed by clean cloth with gasoline.

(2) Examination

The parts of the machine may be loose and deformed after long distance transportation with jolt though every machine is confirmed by strict inspection and test before delivery. A thorough examination must be performed after cleaning the machine. Turn the balance wheel to check if there are running obstruction, parts collision, uneven resistance or abnormal noise. If any of these exist, adjustment must be made accordingly before running.

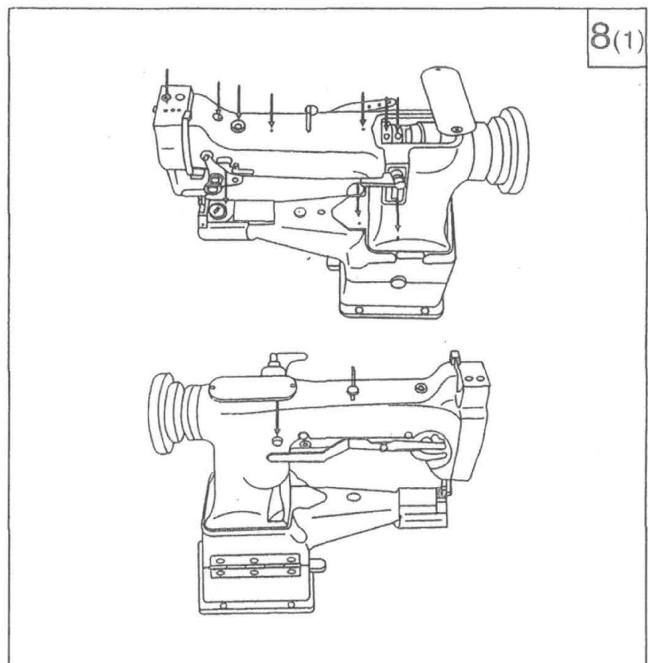

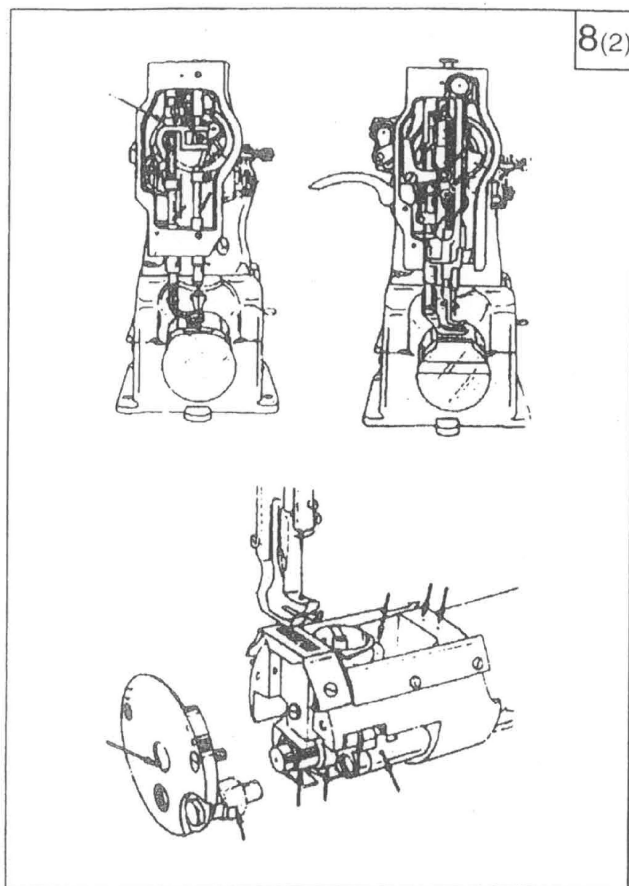

8(2)

10. Lubrication (Fig. 8)

Before running, the machine must be oiled at the places by arrow as shown Fig.8. If the machine continues in operation, it should be oiled not less than twice per shift. Please use HA-8 sewing machine oil or TJ-7 machine oil.

11. Trial run

Trial running is required when new machine is put in to use or use again after operation for quite long time. Please lift the presser foot and run the machine at low speed of 1000-1500 s.p.m for 30 minutes, then increase the speed gradually.

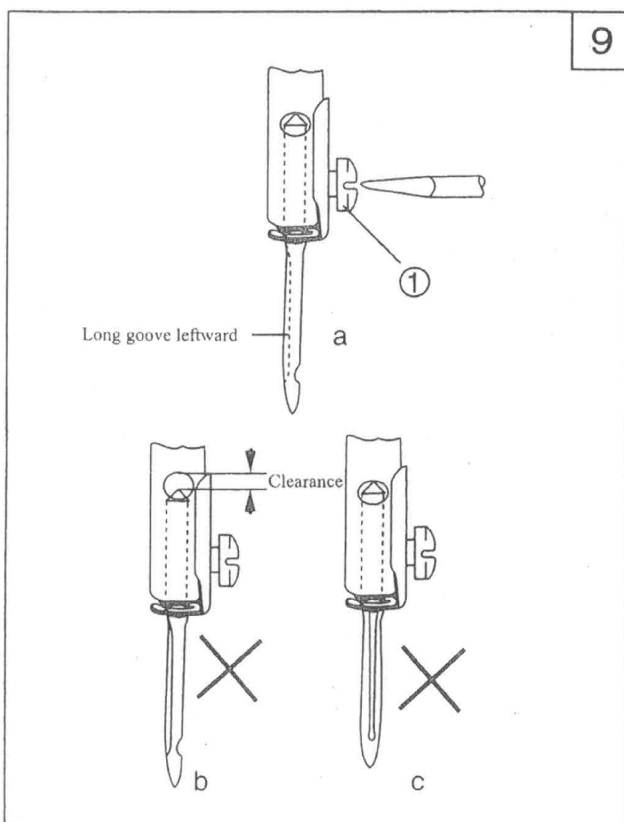

9

12. Installing the needle (Fig. 9)

Turn the balance wheel to lift the needle bar to its highest position, loosen the needle set screw 1, make the needle groove turn to the left side of the operator, fully insert the needle shank to the bottom of needle socket, then tighten the set screw 1.

Note: Fig.9b, insufficient insertion.

Fig.9c, wrong direction of groove.

13. Coordination among the needle, the thread and the material (Fig. 10)

The thread should be left-handed. Holding the thread (shown as Fig 10), twist it upward by right hand, if it changes into twice, it's right-handed, contrary, it's left-handed.

Needle number is DPx17,18# ~ 23#. The needle size should depend on the materials to be sewn. If the thin needle is used for sewing heavy material, the needle will be broken easily, and also will cause skip and thread broken. On the contrary, the material will be destroyed for the big needle hole. So please select proper needle according to the material.

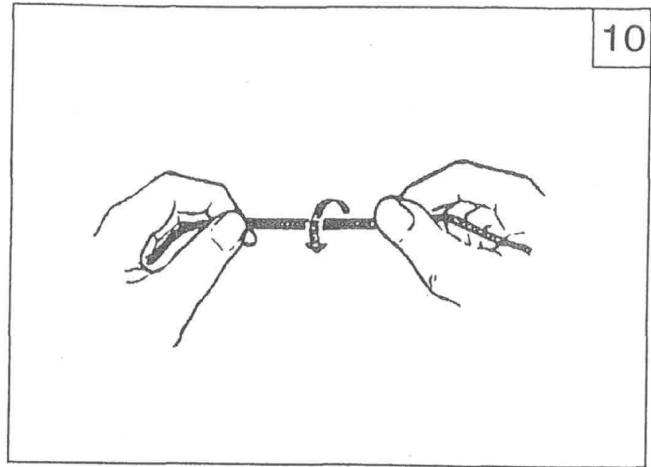

10

14. Threading the needle thread (Fig.11)

Turn the balance wheel to lift the thread take-up lever to the highest position.

The order as Fig .11: Thread pass-by pin A-Three-eye thread guide B - Thread tension C - Thread controller plate D-thread take-up spring E-Upper thread guide F-Thread take-up lever - Upper thread guide F- Middle thread guide H-Lower thread guide I-Needle bar thread guide J-Needle K.

When drawing the bobbin thread, hold the tip of the needle thread by hand, turn the balance wheel to lower the needle bar, then lift it to its highest position. Pull the needle thread and the bobbin thread is drawn up. Put the tips of the needle thread and bobbin thread toward front under the presser foot.

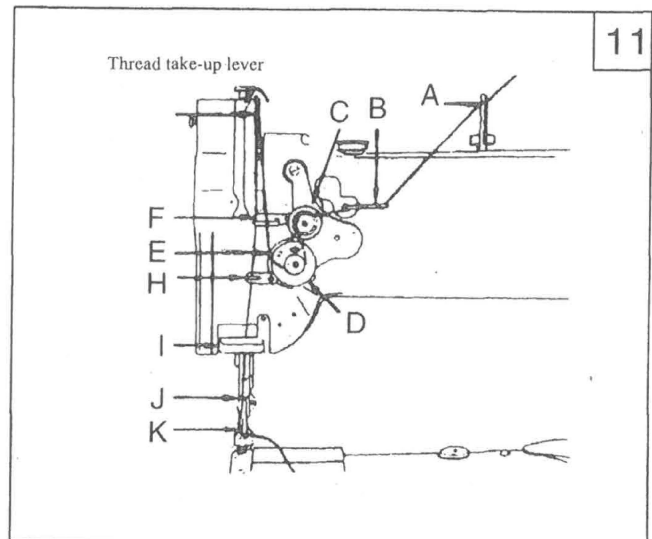

11

15. Adjusting the tension of bobbin thread and needle thread (Fig. 12)

The tension of the needle thread and bobbin thread should be suitable. The stitch form shown as (1) is the best. The abnormal stitch forms shown as (2),(3) will occur when the tension is tightened or loosened.

(1) Adjusting the tension of bobbin thread.

The tension of bobbin thread should be adjusted according to the material.

- ① Turn the balance wheel by hand to lift the thread take-up lever up to its highest position.
- ② Take down the sliding plate, the adjusting screw (A) is shown as 1.
- ③ Turn the adjusting screw (A) clockwise with the screw-knife to increase the tension.
- ④ Turn the adjusting screw (A) counter-clock wise to decrease the tension.

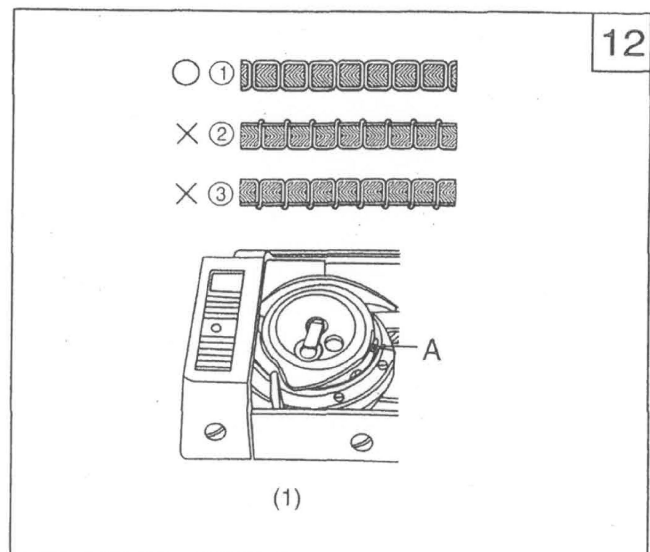

12

12

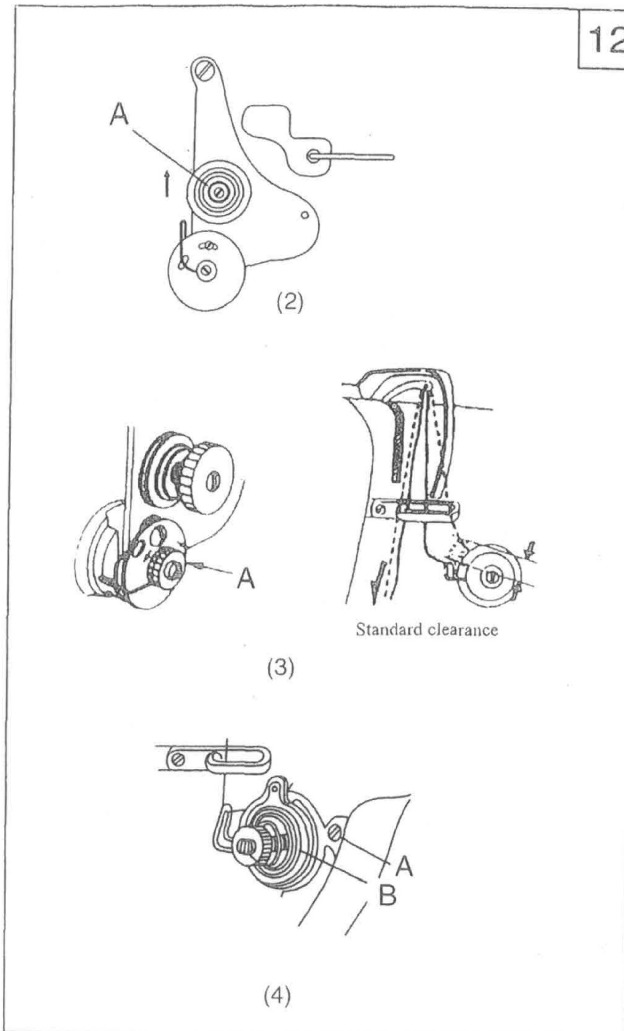

(2) Adjusting the tension of needle thread

① Adjust the pressure on the thread tension disc Adjust the pressure on thread tension disc to change the tension of needle thread. As Fig.(2), turn the nut(a) clockwise to increase the pressure, contrary, to decrease the pressure.

② Adjust the tension of thread take-up spring

Thin material 20g

Common material 25g

Heavy material 30g

The method of adjusting:

loosen the nut A, turn the thread take-up spring shaft counter clockwise to increase the tension. Turn it clockwise to decrease the tension.

③ The swing range of thread take-up spring

The thread take-up spring need to be able to swing when the thread take-up lever is at its highest position.

The normal swing range of the thread take-up spring should be:

Thin material over 8mm

Common material about 8mm

Heavy material less 8mm

The method of adjusting swing range

① loosen the presser foot lever;

② loosen the screw A;

③ Turn the thread take-up spring position disc B counter clockwise to increase the swing range, contrary, the swing range decrease.

④ Tighten the screw A.

13

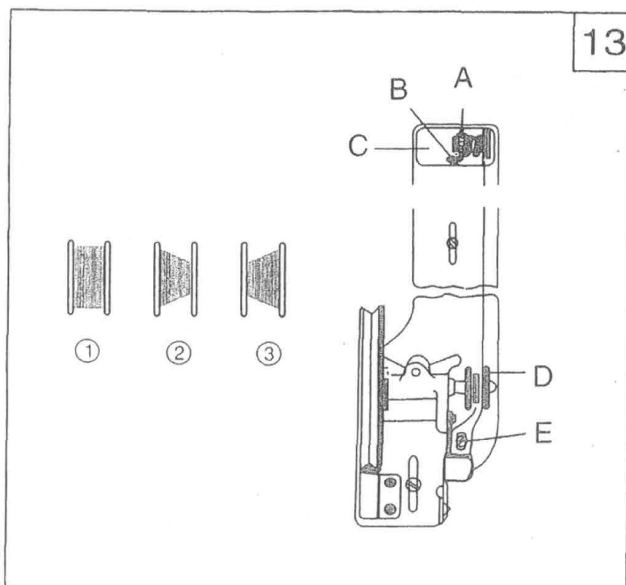

16. Winding the bobbin thread and adjustment (Fig. 13)

The bobbin thread should be neat and tight. If the thread is weak, please enlarge the pressure of the big thread tension disc A. If the thread is not neat, please move the bracket to adjust it. Firstly, loosen the screw B, if the thread is wound to one side as Fig.(2); please move the bracket rightward; if it is as Fig.(3), please move the bracket leftward. Move the bracket until the thread is wound neatly as Fig.(1), then tighten the screw.

Note: Nylon or polyester thread should be wound with light tension in particular, otherwise the bobbin D might be broken or deformed. Don't overfill the bobbin thread, because it makes thread loosen down from the bobbin. The optimum capacity of bobbin thread is fill about 80% of bobbin outside diameter, and this can be adjusted by screw(E).

17. Stitch length and forward and backward feeding (Fig. 14)

Turn the stitch length regulating nut to adjust the stitch length. When the graduation on the stitch Length regulating position block is aligned with the figure on the stitch length graduated plate, the figure is the stitch length. Press the reverse feed lever, the feeding is reverse. Release the lever, the machine recovers normal feeding again.

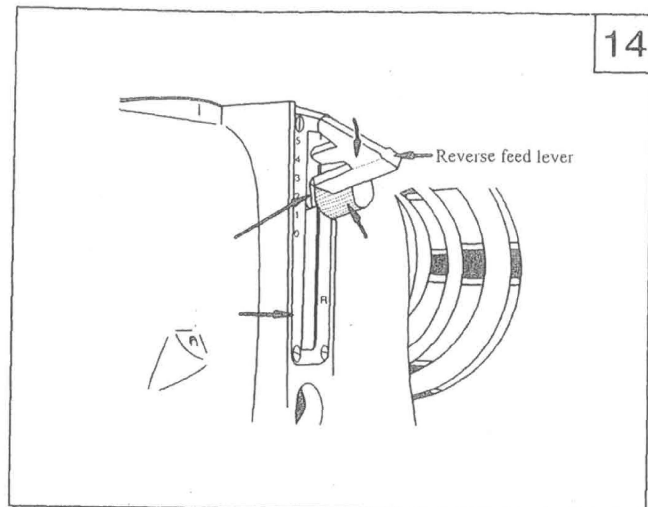

18. Adjusting presser foot pressure (Fig. 15)

Adjust the presser foot pressure according to the material. Please increase the pressure, when you sew heavy material. Turn the regulating screw clockwise to increase the pressure, contrary, decrease the pressure.

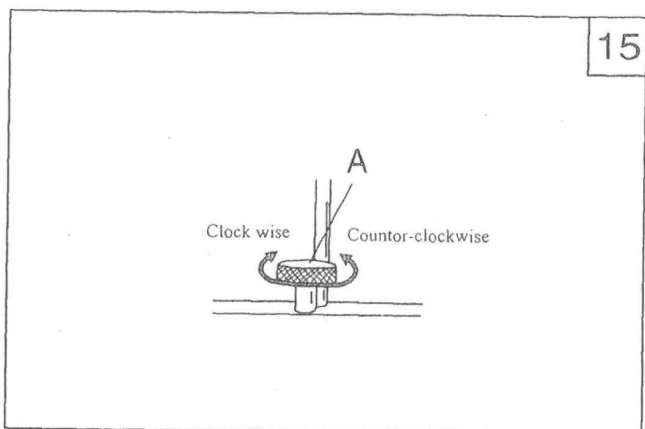

19. The function of the safety clutch and its using (Fig. 16)

The function of the safety clutch is preventing the hook and synchronous belt from destroys when the needle or thread is drawn into the hook for abnormal load during the operation.

When the eccentric pin arrow is aligned with the lower shaft center, the load on the safety clutch is small, increase the load when the arrow turns outside. Reset the safety clutch, the method is : Press the button B by left hand, and turn the balance wheel clockwise by right hand. When the stop plate stops the balance wheel, please turn the balance wheel to make the safety clutch return to the correct position, then release the button. And the synchronous belt should be installed again. At first, turn the balance wheel counter-clockwise when the thread take-up lever is on its highest position, and the red arrow in aligned with the arrow on the position plate,

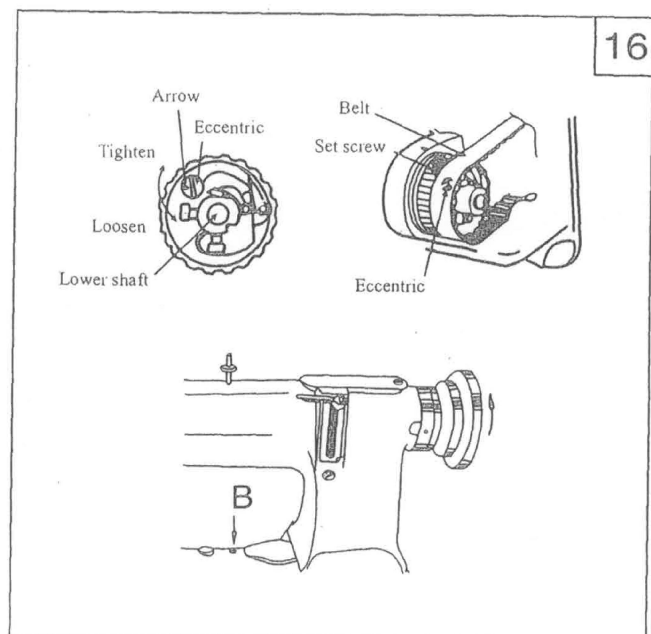

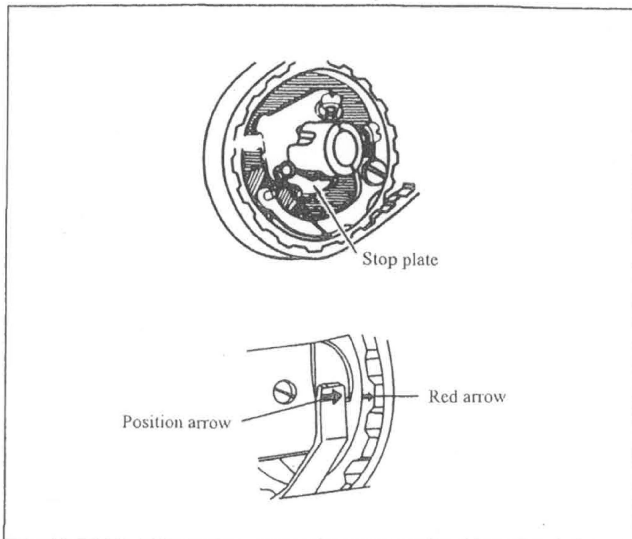

and then install the synchronous belt on the wheel.

20. Adjusting the presser foot lift volume (Fig. 17)

The method of adjusting the presser foot lift volume during the sewing is:

Loosen the nut A, adjust the center distance B between screw and shaft; Adjust the distance B short to increase the presser foot lift volume. Contrary, decrease the presser foot lift volume. Then tighten the screw after adjustment. Turn the upper shaft to check if there is any collision. Begin to use when every thing goes well.

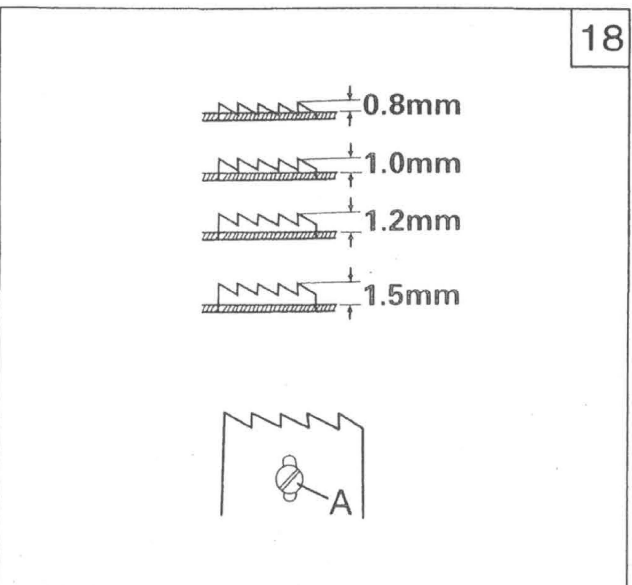
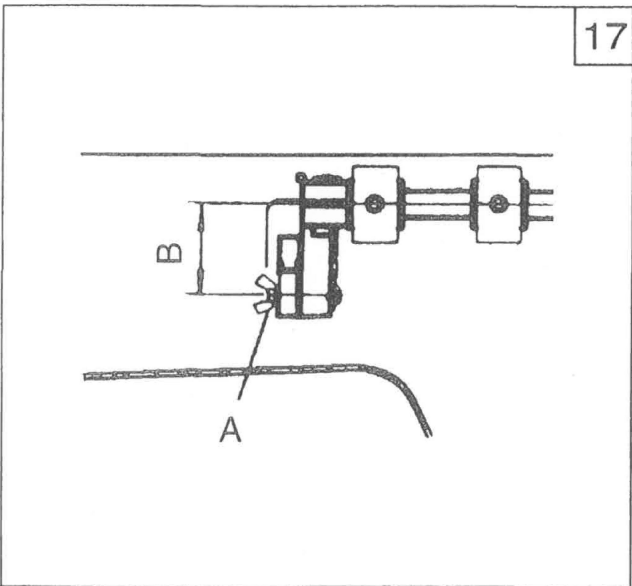

21. Adjusting the feed dog height position (Fig. 18)

Adjust the feed dog height according to the material. The feed dog height is 1.2mm for sewing leather or other heavy material; 0.8mm for sewing thin material; 1.5mm; for sewing extra heavy material. When adjusting the height, firstly loosen the screw A, move the feed dog to proper height, then tighten the screw.

22. Adjusting the timing of feed (Fig. 19)

① Standard position:

When the feed dog appears from the needle plate and begins to feed, the needle should move downward, and is nears the needle plate and aligns with the hole on the plate. Please adjust the position of feed cam and rock shaft crank to adjust the timing of feed.

② Install the feed cam

At first, adjust the stitch length to zero, and open the upper cover, turn the balance wheel counter clockwise by right hand; divide two screw of the feed cam equally as the oil hold is bisector.

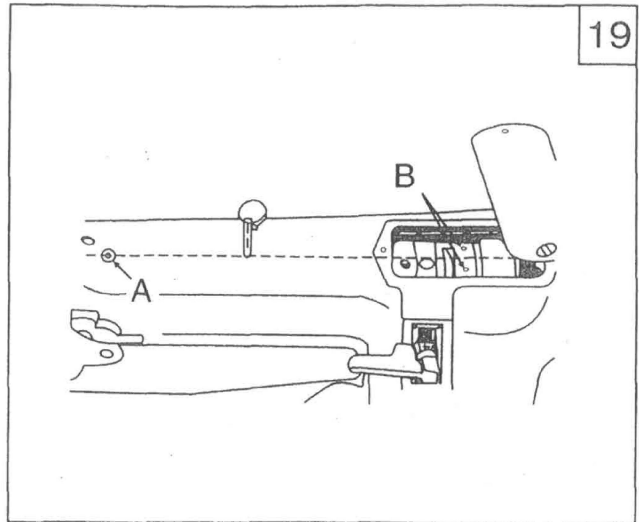

23. Adjusting the timing of needle and hook . (Fig. 20)

The position between hook and needle could be set as following order. Lift the needle up to 2.5mm from its lowest position. The tip of hook should be straight to the needle center, there is about 1.6mm distance between the tip of hook and upside of needle hole. If the position is wrong, please loosen the screw A, move the needle bar up and down until its on proper position. Then tighten the screw. There is distance 0-0.05mm between the tip of hook and needle.

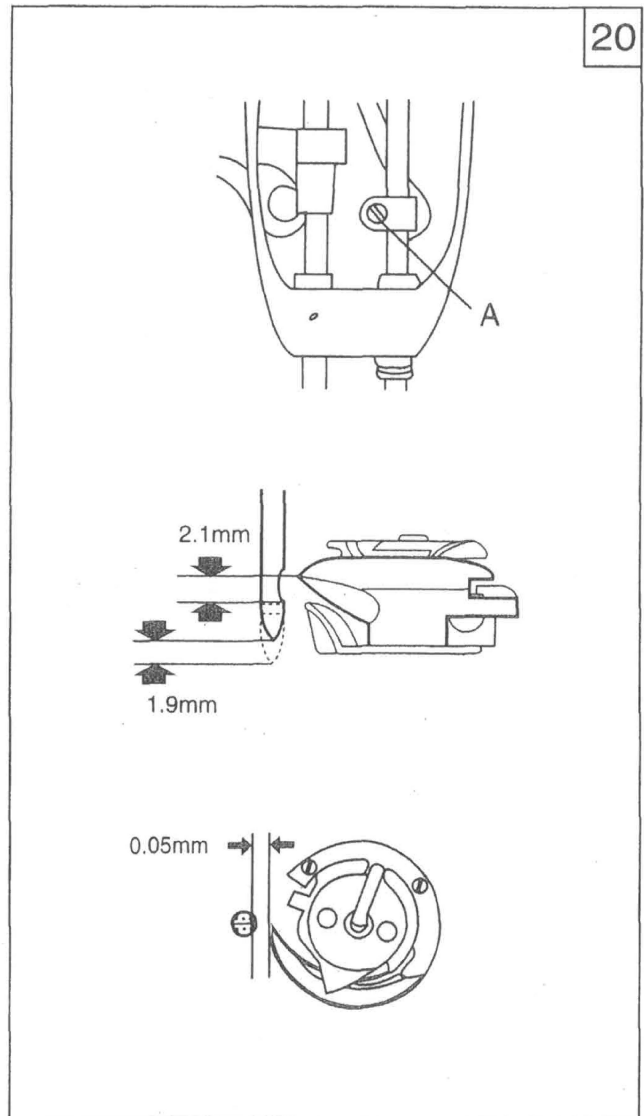

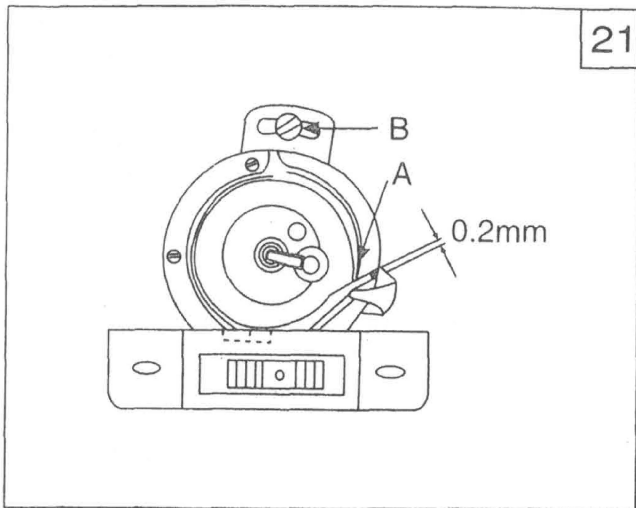

21

24. The relation between the hook and hook thread separate bracket(Fig.21)

- ① Take off the sliding plate.
- ② Turn the balance wheel until the largest clearance between the hook and the thread separate bracket appears.
- ③ Loosen the screw B to make the clearance become 0.2mm.(Please adjust according to the thread.)
- ④ Tighten the screw B.

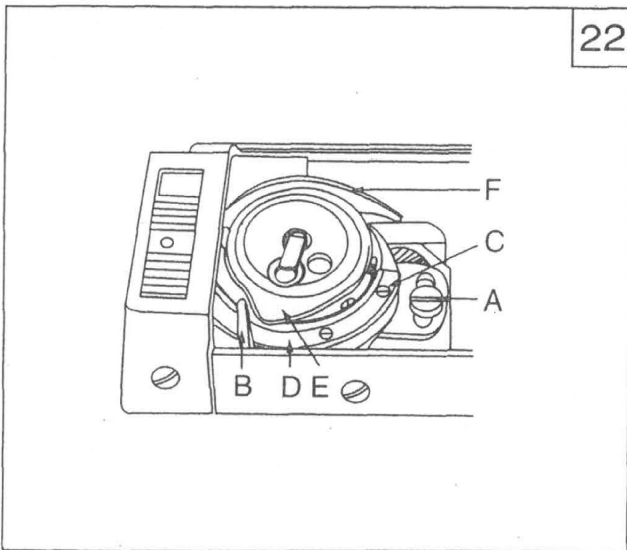

22

25. Installing the hook (Fig.22)

Replace the hook when the hook is damaged.

- ① Turn the balance wheel to make the needle bar move to its highest position, then take down the needle.
- ② Take down the sliding plate, needle plate, front and rear presser cover, bobbin.
- ③ Loosen the regulating screw A, take down the thread separate bracket B.
- ④ Loosen the screw C, take down the cover D.
- ⑤ Slowly move the hook head and take it out.

Install the hook:

Install the hook in the reverse order that the hook is taken down.